

buxton-built

CAGE/BOTTLE WASHERS

Since 1987, Buxton has manufactured Washers to the high-performance and standards expected by healthcare, animal care, laboratories, and bio-pharmaceutical clients.



**Cage/Bottle
Washer
Model 2 Special**

Buxton Washers Feature:

- *Choice of Allen-Bradley Microprocessor or Electro-Mechanical Control Systems*
- *Standard "Off-the-Shelf" Components*
- *Manufactured with Non-Proprietary Parts for Rapid and Cost-Effective Repairs*
- *All Stainless Steel Construction, and Sanitary Piping with Silicone Gaskets and Clamps for Ease of Service and Leak Free Operation*
- *Automatic Drain Feature which Cleans the Drain Strainer During Every Power Drain Cycle*
- *Only Six Moving Parts for Long Term, Trouble Free Performance*
- *Proven Inherent Quality that will Provide Years of Trouble-Free Operation*
- *Unlimited Tap and Mineral Free Water Rinses*
- *Built-In Drying and cGMP Compliance Available*

buxton
buxton
medical
equipment
corporation

1178 Route 109 • Lindenhurst, NY 11757
Phone: 631-957-4500 • Fax: 631-957-3884
www.buxtonmed.com



	Usable Chamber Size	Usable Capacity	Pump Size	Unlimited Rinses	Optional Drying	Optional Multi Level
MODEL 2	32" H x 45" W x 48" D	40.0 Cu. Ft.	7.5 HP	YES	YES	YES
MODEL 9	44" H x 32" W x 44" D	35.0 Cu. Ft.	7.5 HP	YES	YES	YES

Available with Single Door, Double Door, Left/Right Service, and cGMP (Custom Models Available)
 Detailed Installation Drawings are Available Upon Request (Dimensions are Typical Only)

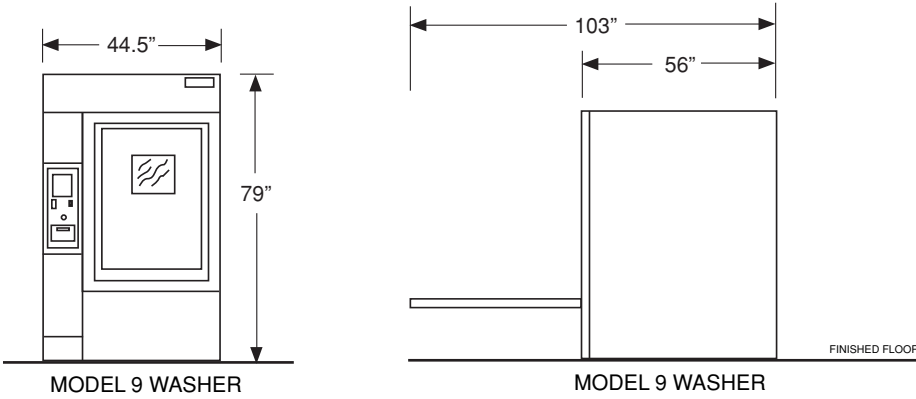
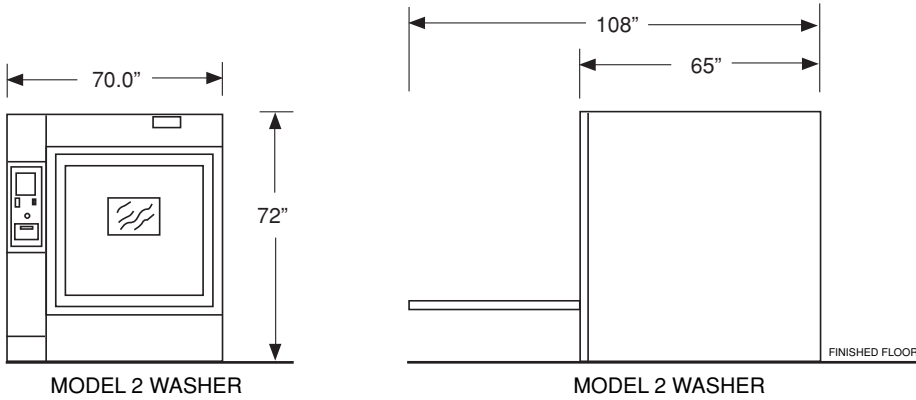

Applications Include...

- Animal Care for Cages and Bottles (Racks Required)
- Pharmaceuticals for Large Glassware and Bottles (Racks Required)
- Biotech for Large Production Items (Racks Required)

Available Options...

- Steam or Electric Heating
- cGMP Compliance Available
- Devapormatic Ventilation
- Automatic Detergent/Acid/Neutralizer Systems
- All T-316 L Stainless Steel